



BIAXIAL FATIGUE TEST FOR TRUCK WHEELS

ES 3.23

Page 1/7

ESSAI BIAXIAL POUR ROUES POIDS LOURD
ZWEIAXIALE PRÜFUNG FÜR LKW-RÄDER

1 - SCOPE

This EUWA Standard specifies a procedure for checking the truck wheels fatigue behaviour by means of a load history that reproduce different driving conditions.

It will be described the test rig type, basic load history and the procedure how to define testing parameters.

2 - FIELD OF APPLICATION

The following standard is valid and has to be used for fully processed new wheels which are representative of wheel intended for the specific vehicles.

The testing procedure described in this norm is valid only for use of LBF "Biaxial wheel test facility for commercial vehicle" (FhG/LBF – Patent EP 00 63 245, US 44 75 383).

The wheel diameter range is lower down limited at 17.5"; wheels below this limit are out of the scope of this norm. The procedure shall be applied only to steel and aluminium alloy wheels.

Wheel's nomenclature and designations are based on ISO 3911.

3 - TEST RIG

The test rig shall be same as LBF "Biaxial wheel test facility for commercial vehicle" (FhG/LBF – Patent EP 00 63 245, US 44 75 383).

Refer to figure 1.

The machine is made of a drum (1), connected to the machine main frame by means of bearings, two actuators, mounted on the machine main frame and connected to the loading frame (4). On the loading frame is mounted the vehicle dummy shaft suitable for "wheel end" fixing. The two actuators are acting in perpendicular directions: horizontal and vertical. The vertical actuator (3), free of sliding in horizontal direction, is connected to the loading frame by means of a hinge while the horizontal one (2), fixed to the machine frame, is linked with loading frame by means of a connecting rod (5).

The wheel rolls inside the driving drum while loaded by the actuators. Inside the drum two side rings offer reaction to the tyre while horizontal force is acting. The wheel tilts according to actuator forces and position of connecting rod pivot (6) on loading frame.

A block program, describing vertical and horizontal load, running in a computer is repeated until test termination.

Main changes compared to the last issue:

4 - LOAD PROGRAM

The “LBF Load program Eurocycle: front axle wheels, Truck” (the Program) here described has been developed by “LBF Fraunhofer Institut für Betriebsfestigkeit FhG” (LBF) who remain only owner of it. The Program must not be used without written permission of LBF. LBF take no responsibility for any damage that may derive from the usage of the Program.

LBF Load program Eurocycle: front axle wheels, Truck. (Annex 1)

The program is made of load sequences. For each sequence it is specified: number of drum revolutions, vertical and horizontal cylinder force.

5 - TESTING PARAMETER

Most important testing parameters are vertical and lateral force coefficients (C_v and C_l) and pre tilt (γ). All other parameters are constant and will be described in the testing procedure.

To adapt the basic program to the specific vehicle multiply basic program loads by the corresponding coefficient (C_v or C_l).

Pre tilt is used to compensate differences in tyre rolling radius and is dependent on the machine geometry. The reference tyre is 315/80 R 22.5 with rolling radius R_0 . Given a tire with rolling radius R ,

$$\gamma = 350 - R_0 + R .$$

In case a displacement flange is used, to shift up the hub spindle, the distance L between wheel axle and dummy vehicle axle shall be added to pre tilt:

$$\gamma = 350 - R_0 + R + L .$$

In annex 2 standard wheels testing parameters are listed.

In case new testing parameter are needed, C_v and C_l shall be supplied or validated by the vehicle manufacturer.

In case the vehicle manufacturer supply the maximum design loads ($F_{v,D}$ $F_{l,D}$) and specify the load program, C_v and C_l are calculated as follow: $C_v = F_{v,D} / F_{v,E}$ and $C_l = F_{l,D} / F_{l,E}$ where $F_{v,E}$ $F_{l,E}$ are Basic Program loads.

6 - TESTING PROCEDURE

6.1 – TEST PREPARATION

The wheel shall be prepared with the proper tyre fitted and valve mounted.

Inflation cold pressure shall be 9 bar.

The wheel shall be installed in the machine with original fasteners and using the vehicle manufacturer specified nut torque.

Original or a representative¹⁾ hub should be used if available.

The dummy vehicle axle shall be adjusted to set the wheel centre in line with the vertical actuator.

The drum side ring position shall be adjusted to limit the tyre thread rooming with a small margin (10-20 mm per side).

Shock absorber connected to the loading frame shall not limit all its possible movements during test execution.

Parameters Cv, Cl and γ shall be properly adjusted.

The foreseen load program shall be loaded in the control computer.

6.2 – TEST EXECUTION

The load program shall be repeated until test termination.

After 1000 km test the nut torque shall be readjusted to the specified value.

In case of wheel failure doubts and neighbours functionality loss, record the residual nut torque and un-mounting the wheel for a deep check.

Crack detection method shall be dye penetration.

After that the nominal mounting conditions and control procedure described above have to be repeated.

6.3 - TEST TERMINATION DEFINITION

6.3.1 Inability of wheel/rim to sustain load.

6.3.2 Inability of wheel/rim to sustain tyre pressure.

6.3.3 Failure of wheel neighbour components with wheel damaging (hub, fasteners, tyre,...).

6.3.4 Successful termination.

Required fatigue-life is shown in table 1.

Nut torque loss, at the end of the test, shall be less than 30% of initial torque.

Note:

¹⁾ In case a non representative hub is used test results may be invalid

Material	Diameter	Design Life	Nr. Of Tests	Test Life	Test Termination
Ferrous	D = 17.5"	600,000 km	2	12000 km	Wheel in full functionality, Short technical cracks allowed.
			1	18000 km	Wheel in full functionality, Cracks allowed.
	D > 17.5"	1,000,000 km	2	16000 km	Wheel in full functionality, Short technical cracks allowed.
			1	24000 km	Wheel in full functionality, Cracks allowed.
Aluminium alloy	D = 17.5"	600,000 km	2	15000 km	Wheel in full functionality, Cracks not allowed.
			1	22500 km	Wheel in full functionality, Short technical cracks allowed.
	D > 17.5"	1,000,000 km	2	20000 km	Wheel in full functionality, Cracks not allowed.
			1	30000 km	Wheel in full functionality, Short technical cracks allowed.

TABLE 1

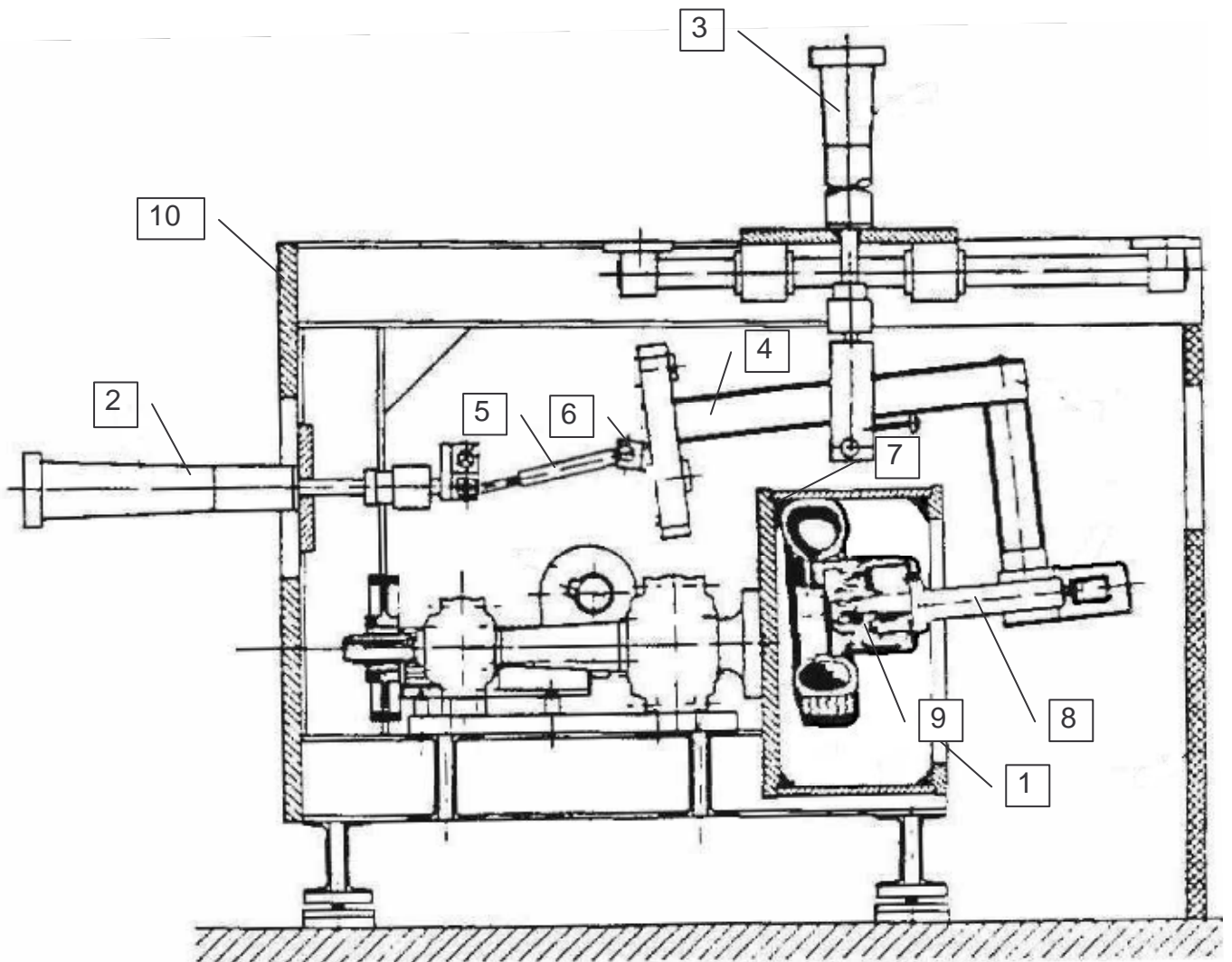

- 1 Drum
- 2 Lateral actuator
- 3 Vertical actuator
- 4 Loading frame
- 5 Horizontal actuator – Loading frame connecting rod
- 6 Connecting rod pivot on loading frame
- 7 Drum side rings
- 8 Dummy vehicle axle
- 9 Wheel end
- 10 Main frame

Figure 1 - LBF “Biaxial wheel test facility for commercial vehicle”
 (FhG/LBF – Patent EP 00 63 245, US 44 75 383).

ANNEX 1

1. LBF1: Load program Eurocycle “Front axle wheels, Truck”.

Basic program load: $F_{v,stat} = 30 \text{ kN}$, $F_{v,E} = 60 \text{ kN}$, $F_{l,E} = 29 \text{ kN}$

SQ	N ²⁾	Fv [kN]	Fh [kN]
1	100	37,50	0,00
2	40	50,00	27,50
3	85	25,00	7,50
4	230	37,50	0,00
5	40	62,50	29,00
6	40	37,50	0,00
7	30	58,00	32,00
8	95	32,50	-7,50
9	80	52,50	24,00
10	95	25,00	-7,50
11	85	50,00	27,50
12	300	37,50	0,00
13	195	38,75	15,00
14	75	31,00	0,00
15	75	46,00	21,00
16	55	25,00	-10,00
17	205	37,50	10,00
18	60	70,00	20,00
19	80	50,00	23,00
20	55	22,50	-7,50
21	170	37,50	2,50
22	70	55,00	25,00
23	20	55,00	25,00
24	110	35,00	-3,70
25	30	35,00	10,00
26	25	50,00	30,00
27	150	35,00	-6,20
28	20	70,00	32,00
29	150	35,00	0,00
30	50	65,00	30,00
31	130	42,50	0,00
32	65	65,00	12,00
33	65	65,00	-12,00
34	65	45,00	6,00
35	65	45,00	-6,00
36	65	65,00	0,00
37	65	42,50	0,00
38	4325	35,00	0,00
39	35	55,00	25,00
40	115	35,00	-10,00
41	130	40,00	7,50
42	20	40,00	18,00
43	65	32,50	0,00
44	30	40,00	22,50
45	250	32,50	0,00
46	45	50,00	27,00
47	75	37,50	5,00
48	35	30,00	-10,00
49	60	37,50	5,00

SQ	N ²⁾	Fv [kN]	Fh [kN]
50	35	25,00	-10,00
51	70	37,50	0,00
52	30	85,00	39,00
53	105	34,00	-7,50
54	30	55,00	25,00
55	40	42,50	10,00
56	25	50,00	28,00
57	15	25,00	-10,00
58	35	35,00	0,00
59	25	25,00	-10,00
60	15	40,00	18,00
61	55	30,00	-10,00
62	30	55,00	27,50
63	15	30,00	-10,00
64	80	40,00	0,00
65	55	30,00	-10,00
66	45	55,00	27,50
67	25	25,00	-10,00
68	60	40,00	0,00
69	30	25,00	-10,00
70	50	40,00	0,00
71	20	55,00	27,50
72	45	30,00	0,00
73	50	60,00	27,50
74	130	42,50	0,00
75	65	65,00	12,00
76	65	65,00	-12,00
77	65	45,00	6,00
78	65	45,00	-6,00
79	65	65,00	0,00
80	65	42,50	0,00
81	65	40,00	0,00
82	45	25,00	-10,00
83	70	50,00	23,00
84	240	35,00	10,00
85	40	55,00	25,00
86	4300	54,00	0,00
87	15	70,00	32,00
88	75	40,00	10,00
89	105	25,00	-10,00
90	600	35,00	0,00
91	40	40,00	15,00
92	50	40,00	0,00
93	30	50,00	15,00
94	40	35,00	-10,00
95	20	40,00	20,00
96	15	25,00	-10,00
97	15	45,00	21,00
98	170	37,50	0,00

Note:

²⁾ This load program has been developed for 1.3 m drum diameter.

ANNEX 2

2. Standard Wheel testing parameter.

Load Program	Wheel	Fstat [kN]	Cv	CI	TYRE
LBF 1	17.5"x6.00	16.5	0.55	0.47	225/75 R 17.5
LBF 1	17.5"x6.75	17	0.57	0.49	225/75 R 17.5
LBF 1	17.5"x6.75	18.5	0.61	0.52	225/75 R 17.5
LBF 1	17.5"x6.75	21.2	0.7	0.6	235/75 R 17.5
LBF 1	17.5"x6.75	23.6	0.75	0.65	235/75 R 17.5
LBF 1	19.5"x6.75	25	0.75	0.65	265/70 R 19.5
LBF 1	19.5"x7.5	28	0.8	0.75	285/70 R 19.5
LBF 1	19.5"x7.5	29	0.83	0.78	285/70 R 19.5
LBF 1	19.5"x8.25	30	0.85	0.8	305/70 R 19.5
LBF 1	19.5"x8.25	31.5	0.89	0.84	305/70 R 19.5
LBF 1	19.5"x8.25	30.75	0.87	0.82	305/70 R 19.5
LBF 1	22.5"x7.5	35.5	1.2	1.2	275/70 R 22.5
LBF 1	22.5"x7.5	32.5	1.1	1.1	275/70 R 22.5
LBF 1	22.5"x8.25	35.5	1.2	1.2	295/80 R 22.5
LBF 1	22.5"x9.00	40	1.3	1.25	315/80 R 22.5
LBF 1	22.5"x9.00	41	1.33	1.28	315/80 R 22.5
LBF 1	22.5"x11.75	45	1.46	1.41	385/65 R 22.5